

# KLP<sup>®</sup> Foundation Blocks



**KLP<sup>®</sup> Foundation Blocks** are designed for lightweight structures such as storage and garden sheds. The easy-to-place plastic foundation blocks offer many advantages over the alternatives from concrete and wood. Seven reasons to choose KLP<sup>®</sup> Foundation Blocks:

1. Quick installation, up to 50% faster than concrete
2. Made from 100% recycled plastics
3. Do not break or rot
4. Expected technical lifetime of at least 50 years
5. Light-weight, only 8 kg per meter!
6. Patented interlocking elements
7. Can be processed in the same way as wood



## Simplicity

The ingenious patented design makes the beam easy to process. The plastic foundation blocks fit seamlessly together. This avoids the necessity of making post-installation adjustments and gives the interior and exterior sides of the garden shed the perfect finish. With three different types of pieces (straight and corner), foundations can be built for structures with practically all dimensions. The foundation blocks can be processed in the same way as wood. Wooden beams or entire wall units can be fastened to the foundations with standard wood screws.



## Health & safety legislation

Compliance with work health and safety legislation is becoming increasingly more important. The overweight of concrete foundation blocks (40 kg) and the related consequences for the health of ground workers on building sites were important reasons behind the development of a plastic alternative. KLP<sup>®</sup> Foundation Blocks have a weight of only 8 kg, so one man can do the job. The KLP<sup>®</sup> Foundation Block saves you time, material and your health.

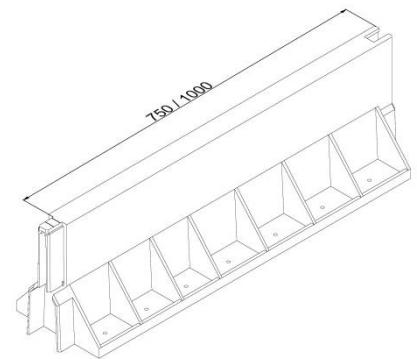
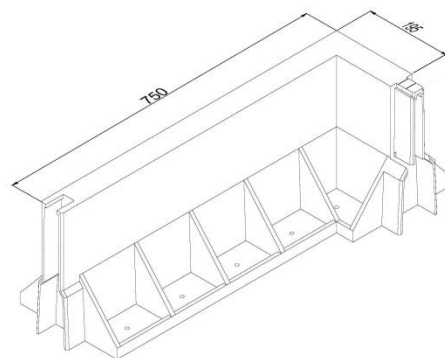

*Durable & Environmentally friendly*



Three types of foundation block are available. All three can be connected to each other to customize your foundation.



If necessary, the foundation blocks can simply be shortened. You will find more information in our technical brochure.



## KLP® Foundation Blocks:

Dimensions	Description
25 x 30 x 75 cm	Straight beam
25 x 30 x 100 cm	Straight beam
34,6 x 30 x 87,2 cm	Corner piece

## Advantages of KLP®:

- Sustainable
- Environmentally friendly
- Maintenance free
- Easy to process
- No rotting or splintering
- Recyclable
- UV, water and weather resistant
- Expected technical lifetime of at least 50 years

*Durable & Environmentally friendly*